

WATER UNIT
 This is for 12 to 24 Volt system vehicles and standby plants, negative earted.

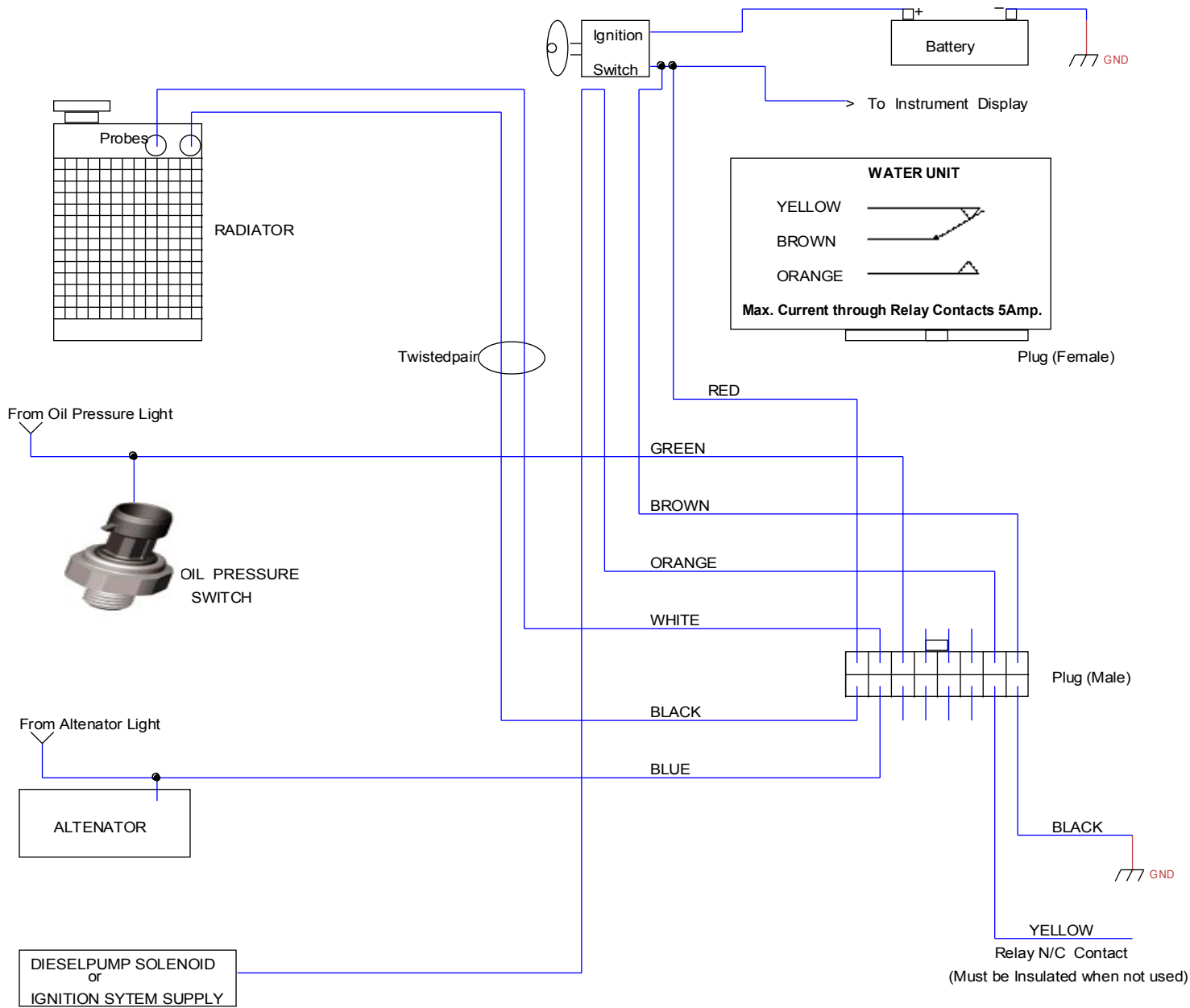

To install the probe: Drill a hole 8 mm (diameter of probe). Make sure the probe does not touch anything in the radiator tank that can cause it to short to ground. Try to ensure a clear area of 10mm around the probe.

To install the two LED'S: Drill 8mm holes where the LED's are to be installed. Push the LED with the wires from the inside through the hole. Push the LED holder (supplied) over the LED till it latch and then push both back into the hole till the holder latch. Be carefull with the wires at the back of the LED'S.

With the exception of the water level monitor, only the preferred options can be used. The wires not in use, must be insulated to eliminate false alarms.

The Relay is energised when all the sensing inputs are OK. The Relay is in the "Engine Off" position when there is no power supplied to the WATER UNIT.

The Unit must not be installed in the engine compartment. It is recommended that it is installed behind the instrument panel.